

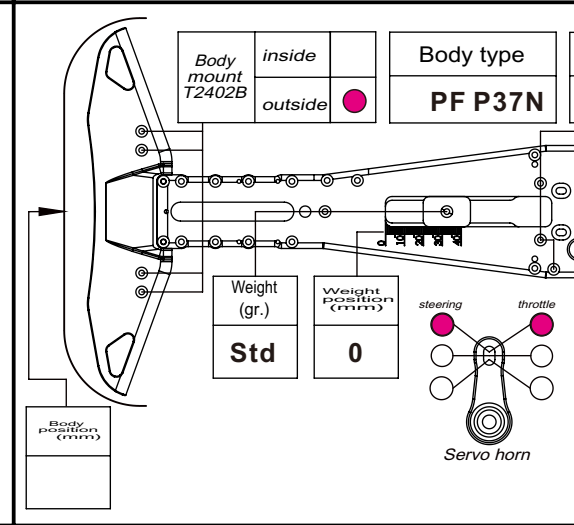

		Tires		Clutch settings		Front shocks		Engine		
Date/Track	2014-11-15 Huge Thailand	Front shore	left Matrix wc / right Matrix wc	Shoe/Bell	Std / Std	Piston	1.1*2	Type	Novarossi Virtus	
Driver	JJ Wang	Rear shore	left Matrix wc / right Matrix wc	Bell clearance (mm)		Oil	600	Plug/Fuel	Plug C6tgf / Fuel Maxima	
Temp. °C.	air / track	Front ∅	left 60 / right 60	Spring/adj. Nut(mm)	Std /	Spring	Ride yellow	Pipe/Manifold	Novarossi / 2660	
		Rear ∅	left 62 / right 62	Bell axial play (mm)					Gear ratio chart	
Track layout/traction	technical <input type="radio"/> low <input type="radio"/>	Differential		Gearing		Piston	1.1*2	Spur Pinion	1st 52 53 54 2nd 47 48 49	
	mixed <input type="radio"/> medium <input type="radio"/>	Front diff. oil cst.	Ride Putty 45	1st gear	15 / 53	Oil	700	1st	14 7,614 7,761 7,907 15 7,107 7,243 7,38	
	fast <input checked="" type="radio"/> high <input checked="" type="radio"/>	Rear diff. oil cst.	80000	2nd gear	20 / 47	Spring	Ride green	2nd	19 5,071 5,179 5,278 20 4,818 4,92 5,023 21 4,588 4,686 4,783	

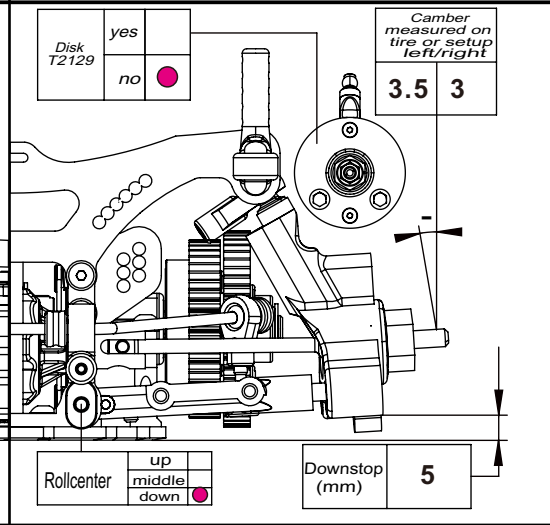
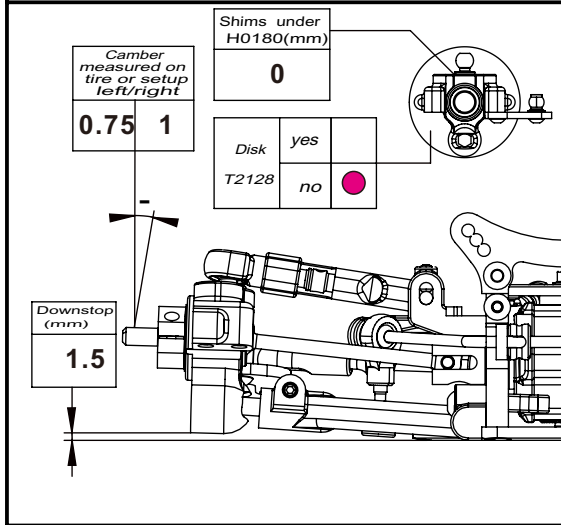
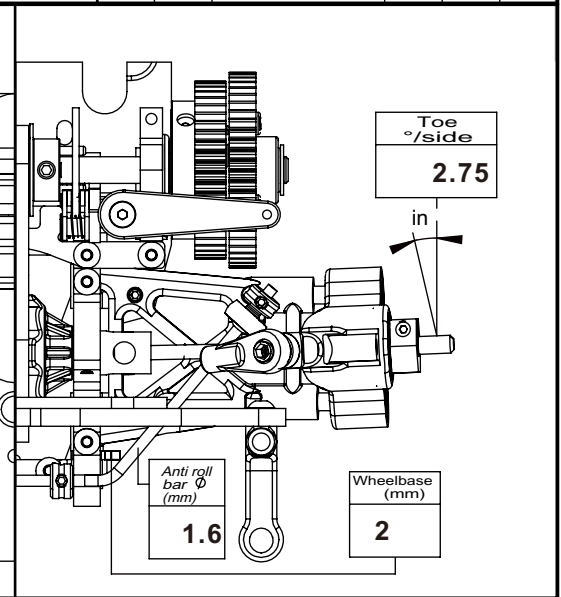
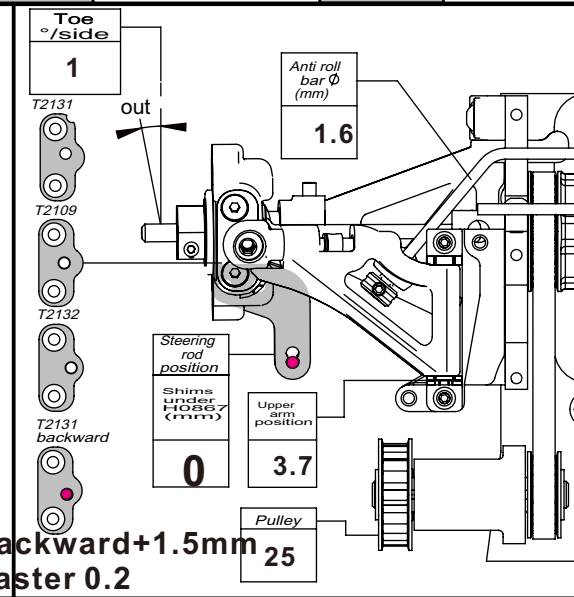
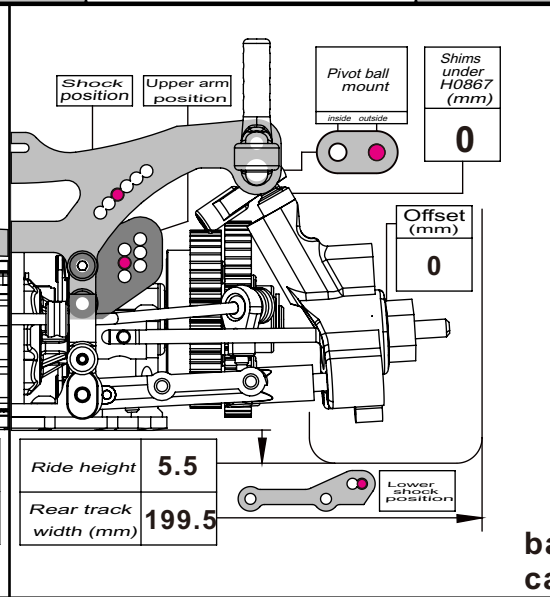
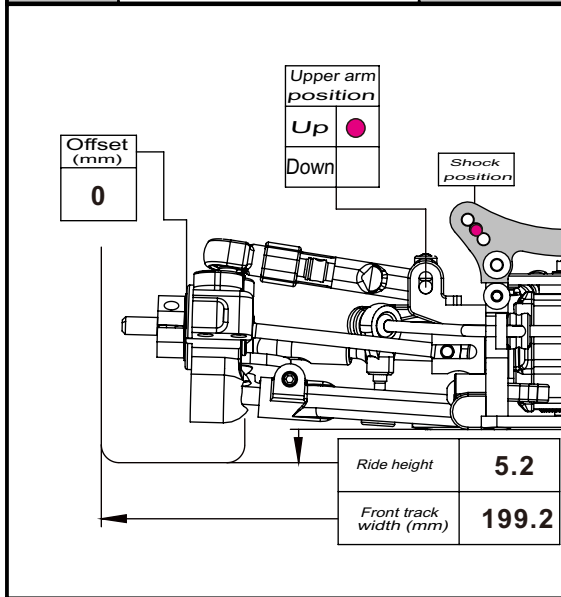

**Note:**  
40g weight in foam bumper